



# ST. ANNE'S

COLLEGE OF ENGINEERING AND TECHNOLOGY  
(Approved by AICTE, New Delhi. Affiliated to Anna University, Chennai)  
(An ISO 9001: 2015 Certified Institution)  
ANGUCHETTYPALAYAM, PANRUTI – 607 106.

## QUESTION BANK

PERIOD: DEC 2018 - MAY 2019

BATCH: 2015 – 2019

BRANCH: ECE

YEAR/SEM: IV/VIII

SUB CODE/NAME: EC6018 - MULTIMEDIA COMPRESSION AND COMMUNICATION

### UNIT I MULTIMEDIA COMPONENTS

#### PART – A



1. What are the multimedia components? [D][Apr/May-2017]

- **Text:** It is the primary component of multimedia. Most of the information can be presented with the help of text. We can be emphasized the text by using different fonts, colors, styles etc.
- **Graphic:** A digital representation of non-text information such as drawing, photographs etc are known as graphics. The graphic medium can be used with text medium.
- **Audio:** Audio is one of the important components of multimedia. It is music, speech or any other sound. It is normally combined with animation medium.
- **Video:** The effective medium for presenting information is video. It presents the moving images. It displayed the sequence of slightly varied pictures at the speed of 15-30 frames per second.
- **Animation:** The animation medium presents the sequence of still images of artwork at a rapid speed that looks like the image is moving.
- **Images :** Images whether represented analog or digital plays a vital role in a multimedia. It is expressed in the form of still picture, painting or a photograph taken through a digital camera.

2. Define luminance. [D][Apr/May-2017]

- ✓ Luminance refers to brightness.
- ✓ Luminance is a measure of the light strength that is actually perceived by the human eye.
- ✓ It describes the amount of light that passes through, is emitted or reflected from a particular area, and falls within a given solid angle.
- ✓ Luminance measures just the portion that is perceived.

3. Differentiate Serif and Sans serif fonts. [D][Nov/Dec-2016] [Nov/Dec-2015] [May/Jun-2016]

S.No.	Serif fonts	Sans serif fonts
1	A font that has decorative corners or stands at the corners is called Serif.	The ones without such decorative corners are called Sans Serif (No Serif) fonts.
2	Serif stands for stroke or line	Serif stands for stroke or line
3	Serif fonts have the extra stroke or decorative design on the end of letters.	Sans-Serif doesn't have any such design or stroke.
4	Example: Times New Roman font.	Example: Arial font.
5		

4. How are 2 1/2 or 2.5 Dimension animations are created? [ID] [Nov/Dec-2016] [Nov/Dec-2015]

2 1/2 D usually referring to an animation created in several flat layers to give some of the depth effects of true 3 – D. Various techniques that are used in creating 2D abstracts are morphing, twining, onion skinning, Anime, and amid rotoscoping.

5. Write the difference between multimedia and hypermedia. [D][Nov/Dec-2014]

**Multimedia** simply can be defined as the use of multiple forms of media to present information. It is an integration of different forms of media such as text, audio, video, images, and still or animated graphics with the computer technology

**Hyper media** is a structured multimedia document or presentation that contains linked multimedia elements through which the users can navigate multimedia content.

6. Mention any four methods for word searching in hypermedia systems. [ID] [Nov/Dec-2014]

- ✓ **Categorical search:** Selecting or limiting the documents, pages, or fields of text within which to search for a word or words
- ✓ **Word relationship:** Searching for the words according to their general proximity and order. Example : “birthday party” and “cake”.
- ✓ **Adjacency:** Searching for words occurring next to one another
- ✓ **Alternates:** Applying an OR criterion to search for two or more words. Example: “meat” or “egg”
- ✓ **Association:** Applying AND criterion to search for two or more words.

7. How are GIF images generated? [D] [May/Jun-2016]

The Graphics Interchange Format (GIF) is a bitmap image format animation. GIFs are made up of a series of images (or frames), and if you already have a bunch of images you'd like to turn into a GIF.

Steps to generate,

- ✓ Upload images: Click the upload button and select as many images as you want.
- ✓ Arrange images: Drag and drop the images selected until it ordered correctly.
- ✓ Adjust options: Adjust the Delay until the speed of your GIF looks normal.
- ✓ Generate the image.

8. What are the responsibilities of interface and information designers in the development of a multimedia project? [D] [Apr/May-2015]

- ✓ An interface designer is responsible for: i) creating software device that organizes content, allows users to access or modify content and present that content on the screen, ii) building a user friendly interface.
- ✓ Information designers, who structure content, determine user pathways and feedback and select presentation media.

9. Write any two advantages of MIDI over digital audio. [D] [Apr/May-2015]

- ✓ MIDI files are much more compact than digital audio files.
- ✓ MIDI files embedded in web pages load and play more quickly than their digital equivalent.
- ✓ MIDI data is completely editable. A particular instrument can be removed from the song and/or a particular instrument can be changed by another just by selecting it.
- ✓ MIDI files may sound better than digital audio files if the MIDI sound source you are using his of high quality

10. Define sampling rate? [D][Nov/Dec-2017]

Sampling rate or frequency is the number of samples per second measured in Hz or kHz.

11. List the members to be in multimedia team. [Nov/Dec-2017]

- ✓ Project Manager
- ✓ Multimedia Designer

- ✓ Interface Designer
- ✓ Multimedia Programmer
- ✓ Computer Programmer
- ✓ Multimedia Writer
- ✓ Video Specialist
- ✓ Audio Specialist
- ✓ Producer for the Web

12. Define Aspect Ratio? [D][EC2037-Nov/Dec-2017]

The ratio of the width to the height of an image or screen is called Aspect Ratio.

13. What is meant by horizontal scanning? [D][EC2037-Nov/Dec-2017]

14. Define Multimedia? [D]

Multimedia is the combination of multiple forms of media like text, graphics, audio, video, images and animation integrated in digital form using computer and software.

15. What are the stages of multimedia application development? [D]

- ✓ Planning and Costing
- ✓ Designing and Producing
- ✓ Testing
- ✓ Delivering

16. Define Hypertext? [D]

Hyper text is a text that provides links to the text in the same or other structured documents.

17. Define formatted text? [D]

Formatted text is any text that contains special formatting such as font size, font color, bold, italic, etc. When copying text, formatted text is any text that keeps its settings from where it is copied. For example, if you copied text that was bold and then pasted it into a program supporting bold text, the text would remain bold. However, if you pasted the text into a program that did not support bold text, the formatting would be removed.

18. Define unformatted text? [D]

Unformatted text is any text that, when copied from the source, may lose its formatting when pasted into another program. It may be pasted as plain text because the source program stripped it of its formatting, or because the target program does not support the original formatting.

19. Define Pixel length? [D]

Pixel Dimensions are the horizontal and vertical measurements of an image expressed in pixels. The pixel dimensions may be determined by multiplying both the width and the height by the dpi. A digital camera will also have pixel dimensions, expressed as the number of pixels horizontally and vertically that define its resolution (e.g., 2,048 by 3,072).

20. Define Bitmap? [D]

A bitmap is a simple information matrix describing the individual dots that are the smallest elements of resolution on a computer screen or other display or printing device.

21. Define Kinematics? [D]

It is the study of the movement and motion of structures that have joints, such as a walking man.

22. What are the different broadcast standards for video? [D]

- ✓ NTSC
- ✓ PAL
- ✓ SECAM

23. Define plain text? [D]

Plain text contains no formatting, only line breaks and spacing. Therefore no text formatting (such as font sizes and colors, bolding or italics) can be used.

24. Define rich text? [D]

Rich Text Format (RTF) is a file format that allows the exchange of text files between different editors. This styled text allows for the addition of formatting, such as font sizes and colors, bolding, italics, etc...

25. Define animation? [D]

Animation is the rapid display of a sequence of images (2D /3D) graphics in order to create an illusion of movement

26. What is the hardware components need for multimedia? [D]

- ✓ Input Devices (Keyboard, Mouse, Touch screen, Scanner)
- ✓ Output Devices (Audio devices, Video devices, Projectors, Monitors)
- ✓ Communication Devices (Modem, Network Devices)
- ✓ Storage Devices (RAM, Hard Disc, Magnetic Tapes, Optical Disc)

27. What is additive color mixing? [D]

In additive color model, a color is created by combining colored light sources in three primary colors: red, green and blue (RGB). This is the process used for a TV or computer monitor

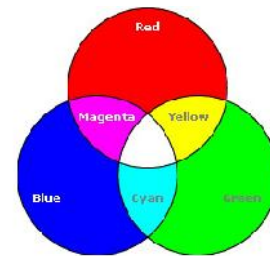

28. What is subtractive color mixing? [D]

In subtractive color method, a new color is created by combining colored media such as paints or ink that absorb (or subtract) some parts of the color spectrum of light and reflect the others back to the eye. Subtractive color is the process used to create color in printing. The printed page is made up of tiny halftone dots of three primary colors, cyan, magenta and yellow (CMY)

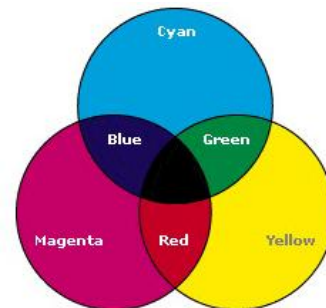

29. What is interactive multimedia? [D]

When the user is permitted to navigate through multimedia elements to choose the required information as in the case of web sites, he has a choice to decide what and when the elements are to be delivered. So he interacts to get information and hence it is called interactive multimedia.

30. What is Tweening? [ID]

Tweening means “in betweening”. The process of creating or drawing a series of intermediate frames in between two key frames to depict an action or trace the path of motion is called tweening.

## PART – B( FIRST HALF)

### Multimedia skills

1. Discuss the skill set needed to develop a multimedia project. Also describe how this is different from the other skill sets? (8) [Nov/Dec-2015] [Nov/Dec-2016]

2. Basic skill set that multimedia team should have. (16)[Nov/Dec-2017]
3. Explain the various multimedia components and some application of multimedia. (16) [Nov/Dec-2017]

### **Multimedia components and their characteristics – Text**

1. Write a short note on 1.Unformatted text(4), 2.Formatted text(4), 3.Hypertext(4), 4.HTML(4) [EC2037-Nov/Dec-2017]
2. Write the importance and attributes of text. (4) [Nov/Dec-2014]
3. Discuss on the text representation techniques. (8) [May/Jun-2016]

### **Multimedia components and their characteristics – Sound**

1. Compare and contrast MIDI and digital audio. (8) [Nov/Dec-2016] [Nov/Dec-2015]
2. Define MIDI and write its attributes and applications in multimedia. (6) [Nov/Dec-2014]
3. Differentiate MIDI and Digital audio. (8) [May/Jun-2016]

### **Multimedia components and their characteristics – Images & Graphics**

1. Explain- the working principle of Digital Camera & scanner with neat block diagram.(16) [Apr/May-2017]
2. You are assigned to create an interface that Looks good across platforms. What is the difference between images as shown on different machines like Mac. PCs etc. How would you deal with those problems? (8) [Nov/Dec-2016] [Nov/Dec-2015]
3. Compare the capabilities and limitations of bitmap and vector images. (6) [Nov/Dec-2014]
4. Describe the capability and limitations of bitmap and vector images. (8) [Apr/May-2015]

## **PART – B SECOND HALF**

### **Multimedia components and their characteristics – Animation**

1. Describe the procedural steps for creating 3D animation with neat sketches. (16) [Apr/May-2017]
2. Give a brief note on computer animation for multimedia applications. (6) [Nov/Dec-2014]
3. Explain any two animation techniques with an example (8) [May/Jun-2016]
4. Explain the technique of computer animation and compare it with the traditional cell animation. (8) [Apr/May-2015]

### **Multimedia components and their characteristics – Video**

1. With the aid of a diagram, explain the term interlaced scanning and progressive scanning in detail. (8) [May/Jun-2016]
2. Explain the interlaced scanning principles of broadcast television(16) [EC2037-Nov/Dec-2017]
3. Write the advantages of digital video over analog video. Discuss the applications of digital video in multimedia systems. (8) [Apr/May-2015]

### **Multimedia components and their characteristics – Hardware.**

1. Explain the modern storage and communication system facilities and their contribution to the development of multimedia systems. (8) [Apr/May-2015]
2. Describe the various output devices available for personal computers and explain how they may be used in multimedia production and delivery. (8) [Nov/Dec-2016] [Nov/Dec-2015]
3. Explain briefly the storage, input and communication devices for multimedia systems. (10) [Nov/Dec-2014]

\*\*\*\*\*

**UNIT II AUDIO AND VIDEO COMPRESSION**  
**PART – A**

1. Define Frequency Masking. [D] [Apr/May-2017]

A louder audio signal of a particular frequency changes the sensitivity of the ear for lower amplitude signals and hence these signals are not perceived i.e they are masked. The masking of low amplitude signals does not depend only on the amplitude but also on the frequency and hence this masking effect is called Frequency masking.

2. What is the principle of adaptive predictive coding? [D] [Apr/May-2017] [EC2037-Nov/Dec-2017]

Adaptive predictive coding (APC) is a narrowband analog-to-digital conversion that uses a one-level or multilevel sampling system in which the value of the signal at each sampling instant is predicted according to a linear function of the past values of the quantized signals

3. What are the different delays suffered by CELP coders? [D] [Nov/Dec-2016] [Apr/May-2015]

- ✓ Processing delay
- ✓ Algorithmic delay

4. What are the advantages of adaptive predictive coding? [D] [Nov/Dec-2016] [Apr/May-2015]

- Even higher levels of compression possible at higher levels of complexity
- The optimum set of coefficients are then computed and these are used to predict more accurately the previous signal
- This compression reduce the bandwidth requirements to 8kbps while still obtaining an acceptable perceived quality

5. How is reversible variable length code words created? [D] [Nov/Dec-2015]

A simple way for producing a set of RVLCs is to first choose a set of VLCs each of which has a constant hamming weight that is each codeword has the same number of binary 1s. The associated set of RVLCs is then produced by adding a fixed length prefix and suffix to each of the corresponding VLC's

VLC	RVLC
1	111
01	1011
001	10011
0001	100011

6. Define signal to mask ratio. [D] [Nov/Dec-2015]

The SMR at a given frequency is expressed as the difference (in dB) between the sound pressure level (SPL) of the masker and the masking threshold at that frequency.

7. Give the principle of DPCM. [D] [Nov/Dec-2014]

- Differential pulse code modulation is a derivative of the standard PCM
- It uses the fact that the range of differences in amplitudes between successive samples of the audio waveform is less than the range of the actual sample amplitudes
- Hence fewer bits are required to represent the difference signals than in case of PCM for the same sampling rate.
- It reduces the bit rate requirements from 64kbps to 56kbps.

8. Write the applications suitable for H.261 standard. [D] [Nov/Dec-2014]

- ✓ Video telephony
- ✓ Teleconferencing over ISDN

9. If the sampling frequency is 1.5 times the true frequency then what is the alias frequency? [ID][May/June-2016]

$$f_{\text{alias}} = f_{\text{sampling}} - f_{\text{true}}$$

$$f_{\text{sampling}} = 1.5 \times f_{\text{true}}$$

$$f_{\text{alias}} = 1.5 f_{\text{true}} - f_{\text{true}}$$

$$f_{\text{alias}} = 0.5 f_{\text{true}}$$

$f_{\text{alias}}$  = alias frequency

$f_{\text{sampling}}$  = Sampling frequency

$f_{\text{true}}$  = True frequency

10. Write down the basic principle of vector quantization technique. [D] [May/June-2016]

Vector quantization (VQ) is a classical quantization technique from signal processing that allows the modeling of probability density functions by the distribution of prototype vectors. It was originally used for data compression. It works by dividing a large set of points (vectors) into groups having approximately the same number of points closest to them.

11. Diagram of differential pulse code modulation encoder and decoder. [D] [Nov/Dec-2017]

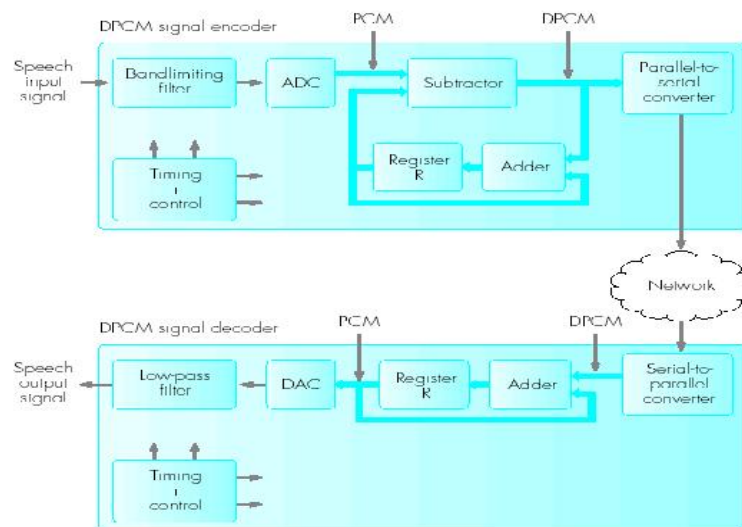

12. Define GOP. Explain its working with an example. [D] [Nov/Dec-2017]

GOP is the abbreviation for Group of Pictures. It is the number of frames / pictures between two successive I frames.

13. Define Temporal Masking. [D] [EC2037-Nov/Dec-2017]

After the ear hears a loud sound, it takes short time before it can hear a quieter sound. This effect is temporal masking.

14. Expand CIF & QCIF? [D]

- ✓ Common Intermediate Format
- ✓ Quarter Common Intermediate Format

15. Write the principle of code excited LPC? [D]

For a limited set of speech segments, features are computed and stored as templates in a Template Code Book. This code book is available both on the encoder and the decoder. The samples in a template are differentially encoded. Each code word transmitted from sending side will select a template that matches best in the codebook available in the decoder side and the speech is reconstructed from this template.

16. Define pitch, period and loudness [D]

- ✓ **Pitch:** this is closely related to the frequency of the signal. This is important since ear is more sensitive to signals in the range 2-5kHz
- ✓ **Period:** this is the duration of the signal
- ✓ **Loudness:** This is determined by the amount of energy in the signal

17. What is the need for compression? [D]

When different types of media like text, image, speech, audio and video are transmitted through communication networks, large bandwidth is required. Similarly when they are to be stored, large memory space will be required. Therefore, these multimedia elements are compressed to reduce the bandwidth & memory requirements and then transmitted or stored.

18. What is DPCM? [D]

Differential pulse-code modulation (DPCM) is a signal encoder that uses the baseline of pulse-code modulation (PCM) but adds some functionalities based on the prediction of the samples of the signal.

19. What is Linear Predictive Coding? [D]

Linear predictive coding is a tool used mostly in audio signal processing and speech processing for representing the spectral envelope of a digital signal of speech in compressed form, using the information of a linear predictive model.

20. What is Code Excited LPC? [D]

Code Excited Linear Predictive Coding is a speech coding algorithm. CELP coders use codebook excitation, a long term pitch prediction filter, and a short term formant prediction filter.

21. What are the different frames in video compression? [D]

- ✓ I frame - Intracoded frame.
- ✓ P frame – Predictive frame
- ✓ B frame – Bidirectional frame
- ✓ PB frame – two neighboring P and B frames are encoded as a single frame.
- ✓ D frame – used for rewind and fast forward operations in video on demand applications

22. Define frame. [D]

An inter frame is a frame in a video compression stream which is expressed in terms of one or more neighboring frames.

23. Write the basic principle of ADPCM. [D]

Instead of using same number of bits to encode the difference values between the samples, ADPCM uses different number of bits to encode the differences based on its value, i.e. smaller difference values use fewer bits and larger difference values use more bits.

24. Define MPEG. [D]

The Moving Picture Experts Group (MPEG) is a working group of authorities that was formed by ISO and IEC to set standards for audio and video compression and transmission.

25. What are the benefits of compression? [D]

Compression reduces the volume of information to be transmitted or stored and hence reduces the bandwidth requirement and memory requirement.



26. What is DVB? [D]

Digital Video Broadcasting (DVB) is a set of internationally open standards for digital television.

27. What is the significance of H.261. [D]

H.261 is a video compression standard defined for using video telephony and video conferencing services over Integrated Services Digital Network (ISDN). This standard permits to use the bandwidth in multiples of 64 kbps. Only I and P frames are used.

28. List the major features of H.263 standard? [D]

It uses QCIF and sub-QCIF digitization formats. Progressive scanning with frame refresh rate of either 15 or 7.5 fps is used. It uses I, P and B frames and provides high level of compression. It provides high frame rate by using PB-frames.

29. List out some of the audio compression standards? [D]

- ✓ G.721: This standard uses DPCM with eight-order predictor with a bandwidth of 3.4 kHz. The difference values are encoded with either 6 bits (32 kbps) or 5 bits (16 kbps).
- ✓ G.722: Uses DPCM and extends bandwidth to 7 kHz using sub band coding. Lower sub band uses 8 kbps sampling rate and higher sub band uses 16 kbps.

30. What is the significance of H.261? [D]

H.261 is a video compression standard defined for using video telephony and video conferencing services over Integrated Services Digital Network (ISDN). This standard permits to use the bandwidth in multiples of 64 kbps. Only I and P frames are used.

**PART – B  
FIRST HALF**

**Audio compression -DPCM-Adaptive PCM**

1. Explain DPCM & Three order predictive DPCM with block diagram.(16) [D] [Apr/May-2017]
2. Discuss the technique of DPCM with neat diagrams. What are the advantages of ADPCM over DPCM? (8) [D] [Nov/Dec-2016]
3. Discuss the methodology of achieving higher levels of compression by making the predictor coefficients associated with the ADPCM adaptive. (8) [D] [Nov/Dec-2015]
4. Draw and explain the adaptive differential PCM encoder and decoder. (8) [D] [Nov/Dec-2014]
5. Discuss the technique of DPCM with neat diagrams. What are the advantages of ADPCM over DPCM? (8) [D] [Apr/May-2015]

**Adaptive predictive coding &linear Predictive coding**

1. Explain the operation of channel vocoders. (8) [D] [May/Jun-2016]
2. Linear predictive coding. (8) [D] [Nov/Dec-2017]
3. Explain Linear Predictive Coding and code excited LPC? (16) [D] [EC2037-Nov/Dec-2017]

**Code excited LPC-perpetual coding**

1. Explain the principle perceptual coders and also explain how they differ from LPC coders. (8) [D] [Nov/Dec-2015]
2. Perceptual coding. (8) [D] [Nov/Dec-2017]
3. The LPC - 10 speech coder's quality deteriorates rapidly with strong background noise. Discuss why MELP works better in the same noisy condition? (8) [D] [May/Jun-2016]
4. Give a brief note on linear predictive coding and code excited LPC. (8) [D] [Nov/Dec-2014]

**PART – B**  
**SECOND HALF**

**Video compression –principles-H.261-H.263**

1. Explain the different types of frames in video compression principles. (16) [D] [Apr/May-2017]
2. Give a brief note on H.263 video compression standard. (6) [D] [Nov/Dec-2016]
3. With the aid of an example explain how DCT blocks are derived from macro blocks in an I frame. (8) [D] [Nov/Dec-2015]
4. Compare the principle and implementation of H.261 and H.263 video compression standards. (8) [D] [Nov/Dec-2014]
5. Explain the process of intra frame and inter frame predictive coding in H.261 algorithm. (8) [D] [May/Jun-2016]
6. Give a brief note on H.263 video compression standard. (6) [D] [Apr/May-2015]
7. Explain the working principles of H.263. (16) [D] [EC2037-Nov/Dec-2017]

**MPEG 1, 2, and 4.**

1. Write a brief note on MPEG perceptual coders. (8) [D] [Nov/Dec-2016]
2. Describe the principle of MPEG 4 with diagrams of encoder and decoder. (10) [D] [Nov/Dec-2016]
3. Explain MPEG 4 encoder/decoder in detail. (8) [D] [Nov/Dec-2015]
4. Discuss the MPEG-4 encoder and decoder with necessary diagrams. (8) [D] [Nov/Dec-2014]
5. How is motion compensation performed in MPEG 4 coding? (8) [D] [May/Jun-2016]
6. Write a brief note on MPEG perceptual coders. (8) [D] [Apr/May-2015]
7. Describe the principle of MPEG 4 with diagrams of encoder and decoder. (10) [D] [Apr/May-2015]
8. Content based video coding principle. (16) [D] [Nov/Dec-2017]

\*\*\*\*\*

## UNIT III TEXT AND IMAGE COMPRESSION

### PART – A

1. Define Entropy encoding. [D] [Apr/May-2017] [May/Jun-2016]  
Entropy encoding is a lossless data compression scheme that is independent of the specific characteristics of the medium. It creates and assigns a unique prefix-free code to each unique symbol that occurs in the input.
2. Define differential encoding. [D] [Apr/May-2017]  
Techniques that transmit information by encoding difference are called differential encoding. Differential encoding schemes are very popular for speech coding.
3. Bring out the differences between loseless and lossy compression. [D] [Nov/Dec-2016]

LOSSY COMPRESSION	LOSSLESS COMPRESSION
Lossy compression will result in a certain loss of accuracy in exchange for a substantial increase in compression. Lossy compression is more effective when used to compress graphic images and digitized voice where losses outside visual or aural perception can be tolerated.	Lossless compression can recover the exact original data after compression. It is used mainly for compressing database records, spreadsheets or word processing files, where exact replication of the original is essential
Transform coding, DCT, DWT, fractal compression, RSSMS.	RLW, LZW, Arithmetic encoding, Huffman encoding, Shannon Fano coding.
Images, audio and video.	Text or program, images and sound.

4. Define the term 'Run length coding'. [D] [Nov/Dec-2016]  
Run-length Encoding or RLE is a technique used to reduce the size of a repeating string of characters. This repeating string is called a run; typically RLE encodes a run of symbols into two bytes, a count and a symbol. RLE can compress any type of data regardless of its information content, but the content of data to be compressed affects the compression ratio. Compression is normally measured with the compression ratio. Create a dynamic Huffman tree for the text "This is Anna University".[Nov/Dec-2015]
5. Derive the binary form of the following run length encoded AC coefficients: (0,6) (0,7) (3,3) (0,-1) (0,0). [ID] [Nov/Dec-2015]

AC coefficients	Skip	SSS/Value
0,6	0	3 110
0,7	0	3 111
3,3	3	2 11
0,-1	0	1 0
0,0	0	0

6. Give the objectives of lossy compression algorithms. [D] [Nov/Dec-2014]  
The main objective of lossy compression is to reduce the number of bits for representing number the source information by introducing acceptable loss of information. It has higher compression ratio.
7. Write the principle of dynamic Huffman coding. [D] [Nov/Dec-2014]  
Adaptive Huffman coding (also called Dynamic Huffman coding) is an adaptive coding technique based on Huffman coding. It permits building the code as the symbols are being transmitted, having no initial knowledge of source distribution, that allows one-pass encoding and adaptation to changing conditions in data.
8. What are the advantages of adaptive Huffman coding over Huffman coding? [D] [May/Jun-2016]

Adaptive Huffman coding (also called Dynamic Huffman coding) is an adaptive coding technique based on Huffman coding. It permits building the code as the symbols are being transmitted, having no initial knowledge of source distribution, that allows one-pass encoding and adaptation to changing conditions in data.

9. When does a codeword said to have prefix property? [D] [Apr/May-2015]  
A code is said to have the prefix property if no codeword is a prefix of any other codeword.
10. Give the principle of differential encoding. [D] [Apr/May-2015]  
Techniques that transmit information by encoding difference are called differential encoding. Differential encoding schemes are very popular for speech coding.
11. Define Run Length Encoding. [D] [Nov/Dec-2017]  
Run length encoding is very simple form of data compression in which consecutive sequences of same data value are stored or transmitted as a single data value and count.
12. If there is a ZIP code file format means which kind of compression technique is used to unzip the data? [ID] [Nov/Dec-2017]  
ZIP is an archive file format that supports lossless data compression
13. Define Lossless compression. [D] [EC2037-Nov/Dec-2017]  
Lossless compression is a class of data compression algorithms that allows the original data to be perfectly reconstructed from the compressed data.
14. What is Huffman code tree? [D] [EC2037-Nov/Dec-2017]  
Huffman coding operation involves creating an unbalanced tree with some branches shorter than the others. The resulting tree is called as Huffman code tree.
15. Define arithmetic coding. [D]  
In arithmetic coding, one to one corresponds between source symbols and code word doesn't exist where as the single arithmetic code word assigned for a sequence of source symbols. A code word defines an interval of number between 0 and 1
16. What is variable length coding? [D]  
Variable Length Coding is the simplest approach to error free compression. It reduces only the coding redundancy. It assigns the shortest possible codeword to the most probable gray levels.
17. What are the types of JPEG modes? [D]
  - a. Sequential mode (Baseline mode)
  - b. Progressive mode
  - c. Hierarchical mode:
18. What are the different compression methods? [D]  
The different compression methods are,
  - i. Run Length Encoding (RLE)
  - ii. Arithmetic coding
  - iii. Huffman coding and
  - iv. Transform coding
19. What is coding redundancy? [D]

If the gray level of an image is coded in a way that uses more code words than necessary to represent each gray level, then the resulting image is said to contain coding redundancy.

20. Use Shannon's formula to derive the minimum average number of bits per character needed to encode the given characters with their probability of occurrence: A and B = 0.25, C and D = 0.14, E, F, G and H = 0.055. [ID]

The minimum average number of bits is obtained by the entropy of the message and it is defined as

$$Entropy(H) = \sum_{i=1}^n P_i \log_2 \frac{1}{p_i}$$

$$\begin{aligned} H &= 2 \times \{ [0.25 \log_2(1/0.25)] + [2 \times \log_2(1/0.14)] + [4 \times 0.055 \log_2(1/0.055)] \} \\ &= 2 \times \{ [0.25 \log_2(4)] + [2 \times \log_2(7.14)] + [4 \times 0.055 \log_2(18.18)] \} \\ &= 2.475 \text{ bits/symbol} \end{aligned}$$

21. Give the general features of entropy coding. [D]

- ✓ Entropy encoding is lossless
- ✓ It is independent of type of information to be compressed. It concerns mainly how the information is represented.
- ✓ e.g. Run-length encoding and Statistical encoding

22. What is entropy of information? [D]

The minimum average number of bits that are required to represent a symbol in a message is known as entropy (H).

$$Entropy(H) = \sum_{i=1}^n P_i \log_2 \frac{1}{p_i}$$

23. State the basic principle of statistical coding. [D]

Statistical coding uses variable length code words for the symbols. Most frequently occurring symbols are assigned less number of bits (smallest code word)

24. Define the term compression ratio. [D]

The data compression ratio is the ratio of the size of the uncompressed data to the size of compressed data.

$$\text{Compression Ratio} = \text{size of uncompressed data} / \text{size of compressed data}$$

25. Give one application each suitable for lossy and lossless compression. [D]

Lossy compression is applied to compress an image or a video whereas lossless compression is applied when a text document is to be compressed.

26. What do you mean by optimum prefix code? [D]

In a set of variable length code words, the shorter code word should not be the start of longer code words. This is called prefix property. The code will be optimum if more frequently occurring symbols are assigned shorter code words compared to less frequently occurring symbols.

27. Write notes on image compression. [D]

Image compression refers to the process of redundancy amount of data required to represent the given quantity of information for digital image. The basis of reduction process is removal of redundant data.

(or)

A technique used to reduce the volume of information to be transmitted about an image

28. What is the result of using a Colour Dictionary in GIF? [D]

The colour dictionary helps to provide higher resolution (24 bits) by using 8-bit colour index values. This reduces the image file size to one third of its original value but the number of colours used for an image will get reduced and approximated to closest colours.

29. What are the basic steps in JPEG? [D]

The Major Steps in JPEG Coding involve:

- i. DCT (Discrete Cosine Transformation)
- ii. Quantization
- iii. Zigzag Scan
- iv. DPCM on DC component
- v. RLE on AC Components
- vi. Entropy Coding

30. How are DC coefficients encoded in a transformed image matrix? [D]

The human eye is responding more to the DC coefficients compared to high frequency AC coefficients. Since DC coefficients are large and important their resolution is kept as high as possible during quantization phase. The DC coefficients vary slowly from one block to the next and hence differential encoding is used to reduce the number of bits used to represent relatively large values.

## **PART – B FIRST HALF**

### **Compression principles-source encoders and destination encoders-lossless and lossy compression entropy encoding –source encoding**

1. Compare a one dimensional coding scheme with a two dimensional encoding scheme. (8) [ID] [Nov/Dec-2015]
2. Explain in detail about lossless and lossy compression. (16) [D] [Nov/Dec-2017]

### **Text compression**

1. Design a Huffman code and find average length for a source that puts out Letters from an alphabet  $A=\{a_1, a_2, a_3, a_4, a_5\}$  with  $P(a_1) = P(a_3) = P(a_4) = 0.1$ ,  $P(a_2) = 0.3$  and  $P(a_5)=0.4$ . (8) [D] [Nov/Dec-2016]
2. A series of message is to be transferred between two computers. The message comprises of the characters A, B, C, D and E. The probabilities of occurrence of the above characters are 0.4, 0.19, 0.16, 0.15 and 0.1 respectively. Use Huffman coding to obtain a codeword for the above characters. Determine the average number of bits per codeword. (10) [D] [Apr/May-2015] (8) [D] [Nov/Dec-2014]

### **Static Huffman coding dynamic coding**

1. Find Huffman codeword of the , given text "AAAAAAAAAABBBBBBCCCSS" by static Huffman tree. Calculate Entropy & Derive the average number of bits per character for codeword? (16) [D] [Apr/May-2017]
2. Describe dynamic Huffman code for the same output source with the above probabilities. (8) [D] [Nov/Dec-2016]
3. Consider the string ARBER, apply Huffman coding and decode it. (16) [D] [Nov/Dec-2017]

4. Find Huffman codeword of the given text “GOOD DAY” by constructing Dynamic Huffman tree? [D] (16)

### Arithmetic coding

1. Generate arithmetic code for the sequence 1233 with cdf  $F_x(1) = 0.8$ ,  $F_x(2) = 0.82$  and  $F_x(3) = 1$ . (8) [D] [Nov/Dec-2016]
2. The symbol probability table is given below. Write the code word for CAEE\$ using Arithmetic Encoding scheme. (8) [D] [May/Jun-2016]

Symbol	A	B	C	D	E	F	\$
Probability	0.2	0.1	0.2	0.05	0.3	0.05	0.1

3. Explain arithmetic coding with suitable example. (16) [EC2037-Nov/Dec-2017]
4. Write the following symbols and probabilities of occurrence; encode the Message “went” using arithmetic coding algorithms. [D] (16)

Symbols:	e	n	t	w	#
Prob :	0.3	0.3	0.2	0.1	0.1

### Lempel ziv-welsh Compression

1. Explain Lempel Ziv Welsh Compression. (16) [D] [Apr/May-2017]
2. Explain in detail about LZW algorithm. (8) [D] [Nov/Dec-2016]
3. Discuss the principle of Lempel-Ziv and Lempel-Ziv-Welsh coding techniques. (8) [D] [Nov/Dec-2014]
4. Explain the principle of operation of LZ compression algorithm. Assume a dictionary of 16,000 words and an average word length of 5 bits; derive the average compression ratio that is achieved relative to using 7 bit ASCII code word. (8) [ID] [Nov/Dec-2015]
5. Let a simple dictionary contain the following string with their respective codes.

String	A	B	C
Code	1	2	3

Now if the input string is ABAABBABCABABBA, how does the LZW compression algorithm work? (8) [D] [May/Jun-2016]

6. Discuss the principle of Lempel Ziv-Welsh coding. (6) [D] [Apr/May-2015]

## PART – B SECOND HALF

### Image compression

1. With the help of a diagram identify the five main stages associated with the baseline mode of operation of JPEG and give a brief description of the role of each stage. (8) [D] [Nov/Dec-2015]
2. With the help of a diagram identify the five main stages associated with the baseline mode of operation of JPEG and give a brief description of the role of each stage. (8) [D] [Nov/Dec-2015]
3. Explain the JPEG encoder and decoder with neat diagrams. (10) [D] [Nov/Dec-2014]
4. Write a brief note on image file formats. (6) [D] [Nov/Dec-2014]
5. Explain the GIF interlaced mode of compression. (8) [D] [May/Jun-2016]
6. Identify the five main stages associated with the baseline mode of operation of JPEG and give a brief description of each stage. (8) [D] [May/Jun-2016]
7. Describe the operation of JPEG encoder and decoder with neat diagrams. (10) [D] [Apr/May-2015]
8. Give a brief note on GIF and TIFF formats. (6) [D] [Apr/May-2015]
9. Explain JPEG image compression technique. (16) [D] [EC2037-Nov/Dec-2017]

\*\*\*\*\*

## UNIT IV VOIP TECHNOLOGY

### PART – A

1. What are the challenges involved in VoIP? [D] [Apr/May-2017] (Or) List the challenges of VOIP. [D] [Nov/Dec-2015] [D] [May/Jun-2016] (Or) Challenges in VOIP. [D][Nov/Dec-2017]

The major challenges of VOIP are good speech quality, low transmission delay, low jitter and low loss of data during transmission and reception.

2. List the types of CODEC. [D] [Apr/May-2017] (Or) Write down the various Audio CODEC methods available. [D] [Nov/Dec-2015] (Or) Summarize all CODEC methods. [D] [EC2037 - Nov/Dec-2017]

- ✓ G.711
- ✓ G.723.1
- ✓ G.729A
- ✓ G.729
- ✓ G.728
- ✓ G.721

3. What is IP transport? [D] [Nov/Dec-2016]

IP (Internet Protocol) is a routing protocol for passing of data packets. IP itself makes no guarantee that a given packet will be delivered. IP is known as “best-effort” protocol. Which means information may be delivered when there is no traffic or discarded when the traffic is heavy.

4. Write notes on SS7. [D] [Nov/Dec-2016]

SS7(Signaling System no.7) enables a wide range of services including caller-ID, toll free calling, call screening, number portability. SS7 is the foundation for intelligent network services. SS7 supports VOIP for many new services.

5. What is meant by Internet telephony? [D] [Nov/Dec-2014] [Apr/May-2015]

Internet telephony is a type of communications technology that allows voice calls and other telephony services like fax, SMS and other voice-messaging applications to be transmitted using the Internet as a connection medium. Internet telephony is also called IP telephony or broadband telephony.

6. What are the services supported by VoIP? [D] [Nov/Dec-2014]

Write the applications of VoIP in multimedia systems.

Give the major applications of VoIP.

- ✓ Internet (IP) Telephony,
- ✓ Video Conferencing,
- ✓ Telephone Answering Systems,
- ✓ Net meeting
- ✓ Multimedia conferencing.

7. Enumerate the equipments needed for IP enabled voice transfer. [D] [May/Jun-2016]

A VoIP phone is necessary to connect to a VoIP service provider. This can be implemented in several ways:

- ✓ Dedicated VoIP phones connect directly to the IP network using technologies such as wired Ethernet or Wi-Fi. These are typically designed in the style of traditional digital business telephones.
- ✓ An analog telephone adapter connects to the network and implements the electronics and firmware to operate a conventional analog telephone attached through a modular phone jack. Some residential Internet gateways and cable modems have this function built in.
- ✓ Soft phone application software installed on a networked computer that is equipped with a microphone and speaker, or headset. The application typically presents a dial pad and display field to the user to operate the application by mouse clicks or keyboard input.
- ✓ Smart phones may have SIP clients built into the firmware or available as an application download



8. What are the different factors that determine the QoS of VoIP systems? [D] [Apr/May-2015]  
 QoS is a collective measure of the level of service delivered to a customer. QoS can be characterized by several performance criteria such as availability, throughput, and connection setup time. QoS can be measured in terms of bandwidth; packet loss delay and jitter.

9. Draw the network architecture for SIP. [D] [Nov/Dec-2017]

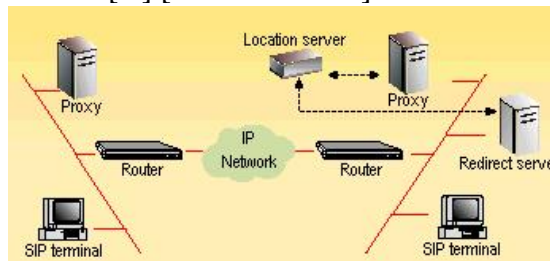

10. Discuss the features of SS7& and its applications. [D] [EC2037 - Nov/Dec-2017]

✓ Features:

- ❖ Flow control
- ❖ Error detection and Retransmission capability
- ❖ Controls for congestion control
- ❖ Peer entity status detection
- ❖ Security mechanism

✓ Applications:

- ❖ PSTN and Mobile services
- ❖ ISDN(Voice and Data)
- ❖ Control points for service control
- ❖ Operation administration and maintenance of networks
- ❖ Interaction with network database and service

11. List the salient features of VOIP technology. [D]

- ✓ Lower Equipment Cost
- ✓ Lower operating expense
- ✓ Widespread availability of IP
- ✓ Potentially lower bandwidth requirements

12. Define the term quality of service. [D]

QoS is a collective measure of the level of service delivered to a customer. QoS can be characterized by several performance criteria such as availability, through put, connection time. QoS can be measured in terms of bandwidth, packet loss band jitter.

13. Define RTP compression. [D]

The combination of the IP, UDP and RTP control information adds up to a significant overhead for small media samples, particularly over low speed links, commonly in use by the domestic and small office user dialling up their Internet Service Provider at a few tens of kilobits per second.

14. Define SSP, STP, and SCP? [D]

Service switching point (SSP) is an end-point used by a telecommunications system such as telephone switches and performs call processing on calls that start, tandem or end at that site.

Service control point (SCP) is a standard component of the Intelligent Network (IN) telephone system which is used to control the service.

Signal Transfer Point (STP) is a router that relays SS7 messages between signaling

15. What is TCAP? [D]

Transaction Capabilities Application Part (TCAP) defines the messages and protocol used to communicate between applications (deployed as subsystems) in nodes. TCAP supports the exchange of non-circuit related data between applications across the SS7 network using the SCCP connectionless service.

16. What is SCCP? [D]

Signaling Connection Control Part (SCCP) is a portion of International Telecommunication Union (ITU) recommendation Q.711, which is the routing protocol for Signaling System 7 (SS7), a set of protocols used to set up calls in telephony networks.

17. Define the protocol suite of SS7. [D]

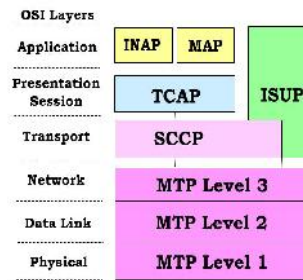

18. Define SS7. [D]

Signaling System 7 (SS7) is an international telecommunications standard that **defines** how network elements in a public switched telephone network (PSTN) exchange information over a digital signaling network. Nodes in an SS7 network are called signaling points.

19. Define SIP. [D]

Session Initiation Protocol (SIP) is a signaling protocol used for initiating, maintaining, modifying and terminating real-time sessions that involve video, voice, messaging and other communications applications and services between two or more endpoints on IP networks.

20. What is SIP message request? [D]

SIP requests are the codes used to establish a communication. To complement them, there are SIP responses that generally indicate whether a request succeeded or failed.

- ✓ INVITE is used to initiate a session with a user agent.
- ✓ BYE is the method used to terminate an established session.
- ✓ REGISTER request performs the registration of a user agent.
- ✓ CANCEL is used to terminate a session which is not established.
- ✓ ACK is used to acknowledge the final responses to an INVITE method.
- ✓ OPTIONS method is used to query a user agent or a proxy server about its capabilities and discover its current availability.

21. What are the characteristics of SIP? [D]

- ✓ Operates at the application layer.
- ✓ Encompasses all aspects of signaling, e.g. location of called party, ringing a phone, accepting a call, and terminating a call.
- ✓ Provides services such as call forwarding.
- ✓ Relies on multicast for conference calls.
- ✓ Allows two sides to negotiate capabilities and choose the media and parameters to be used.

22. Define Gateway. [D]

Voice over Internet Protocol (VoIP) gateway is a device that converts analog telephony signals to digital. After converting the signal, the VoIP gateway organizes it into data packets and encrypts it for transmission.

23. Define Gatekeeper. [D]

A Gatekeeper serves the purpose of Call Admission Control and translation services from E.164 IDs (commonly a phone number) to IP addresses in an H.323 telephony network. Gatekeeper controls interactions for each zone, which comprises the terminals, multipoint control units (MCUs), and gateways within a particular domain.

24. What is IP protocol? [D]

The Internet Protocol (IP) is the principal communications protocol in the Internet protocol suite for relaying datagram across network boundaries. Its routing function enables internetworking, and essentially establishes the Internet.

25. Define TUP? [D]

Telephone User Part (TUP) is an analog protocol that performs basic telephone call connect and disconnect.

26. What is IP transport? [D]

The IP simply passes a data packet from one router to another through the network to the destination. Each packet in the data stream can take different paths in the network and hence they will reach the destination out of sequence with different delays. The IP does not protect against loss of packets.

27. What is a VoIP? (Or) Write the principle of Voice over IP technology. (Or) List the salient features of VoIP technology. [D]

- ✓ Voice over Internet Protocol is the technology used to transfer voice and data through IP in third-generation (3G) networks.
- ✓ It uses packet switching instead of conventional circuit switching used in telephone lines.
- ✓ VoIP can transfer voice at less than 64kbps.
- ✓ IP exists everywhere and supported by computers and many handheld devices.
- ✓ With many voice compression techniques the data transfer rate can be dynamically adjusted according to the network traffic.
- ✓ GUI (Graphical User Interface) can be developed easily to interact with the VoIP applications.

28. Mention the Major challenges involved in implementation of VoIP. [D]

List the challenges involved in VoIP deployment

- ✓ The loss of packets can be minimized to a low value by using TCP. But this will increase the delay for the arrival of packets to the destination and hence causes jitter in the playback. In case if excessive delay, occasional packet losses are permitted and UDP is used to transmit voice packets and reduce the delay. Compatibility should be maintained among the VoIP protocols.
- ✓ VoIP is vulnerable to attacks by worms, viruses and spams.

29. How does call establishment take place in VoIP? [D]

There are many signals used to establish a call in VoIP. Whatever may be the protocol, the caller sends an invite or setup or transaction signal to the called terminal. This is then accepted by the called terminal

by issuing connect or reply signal along with necessary information. Then media transfer takes place. Finally, the connection is closed by issuing release or bye signal.

30. Why is H. 323 protocols designed? [D]

The H.323 is a signalling protocol used in telephony networks. It is designed to communicate a desire to set up a call, establish the call and finally close the call. This is the first set of widely deployed VoIP signalling system.

**PART – B  
FIRST HALF**

**Basics of IP transport, VoIP challenges,**

1. Draw and Explain the VoIP network architecture.(16) [D] [Apr/May-2017]
2. Explain the network architecture and protocols supporting the functionality of VOIP networks. (16) [D] [Nov/Dec-2016]
3. For VoIP to be a realistic replacement for standard public switched telephone network (PSTN) telephony services, customers need to receive the same quality of voice transmission they receive with basic telephone services. How is this achieved? Explain with various qualities of service parameters. [May/Jun-2016]
4. Explain in detail about VOIP. (16) [D] [Nov/Dec-2017]
5. Give a detailed note on challenges in VOIP and its applications. (16) [D] [EC2037-Nov/Dec-2017]

**H.323/ SIP –Network Architecture, Protocols, Call establishment and release,**

1. Explain in detail about the H.323 with the architecture. (16) [D] [Apr/May-2017]
2. Discuss in detail about H.323 and SIP network architectures. (16) [D] [Nov/Dec-2015]
3. Explain the session initiation protocol and write its application for VoIP. (10) [D] [Nov/Dec-2014]
4. Explain briefly the H.323 architecture and protocols. (10) [D] [Nov/Dec-2014]
5. Compare and contrast H.323 and SIP protocols in detail with respect to complexity, reliability, message encoding, scalability and address resolution. (16) [ID] [May/Jun-2016]
6. Explain the H.323 architecture and protocol in detail and write its applications. (10) [Apr/May-2015]
7. Explain in detail about Message format that was used for SIP.(16) [ID] [Nov/Dec-2017]
8. Define and explain the architectures of SIP.(16) [D] [EC2037-Nov/Dec-2017]

**PART – B  
SECOND HALF**

**VoIP and SS7**

1. Explain SS7 protocol suite and also discuss ISUP call establishment and release in detail. (16) [D] [Nov/Dec-2015]
2. Give a brief note on application of SS7 for VoIP services: (6) [D] [Nov/Dec-2014]
3. Describe the principle and architecture of SS7 and discuss the need for SS7 signaling in VoIP. (8) [D] [Apr/May-2015]
4. Give a brief note on CODEC methods. (8) [D] [Apr/May-2015]

**Quality of Service- CODEC Methods- VOIP applicability**

1. Write a brief note on the challenges arid applications of VoIP. (6) [D] [Apr/May-2015]
2. Give a brief note on QoS issues in VoIP. (6) [D] [Nov/Dec-2014]
3. Give a detailed note on : (i) CODEC methods. (8) [D] [Nov/Dec-2016]  
(ii) VOIP applications and its current status. (8) [D] [Nov/Dec-2016]

\*\*\*\*\*

**UNIT V MULTIMEDIA NETWORKING**  
**PART – A**

1. Define Packet Jitter. **[D][Apr/May-2017]**  
Jitter in IP networks is the variation in the latency on a packet flow between two systems, when some packets take longer to travel from one system to the other. ... A jitter buffer (or de-jitter buffer) can mitigate the effects of jitter, either in the network on a router or switch, or on a computer
2. What is meant by RSVP? **[D] [Apr/May-2017]**  
RSVP (Resource Reservation Protocol) is a set of communication rules that allows channels or paths on the Internet to be reserved for the multicast (one source to many receivers) transmission of video and other high-bandwidth messages. RSVP is part of the Internet Integrated Service (IIS) model, which ensures best-effort service, real-time service, and controlled link-sharing
3. What are the limitations of best effort service? **[D][Nov/Dec-2016]**  
The limitations of best-effort service are packet loss, excessive end-To- end delay and packet jitter.
4. What is meant by steaming? **[D] [Nov/Dec-2016]**  
Streaming media is video or audio content sent in compressed form over the internet & played immediately. It avoids the process of saving the data to the hard. By streaming, a user need not wait to download a file to play it.
5. Define any four quality of service parameters related to multimedia data transmission. **[ID] [Nov/Dec-2015]**
  - ✓ Data Rate
  - ✓ Latency
  - ✓ Packet loss or error
  - ✓ Jitter
  - ✓ Sync skew
6. Are the TCP receive buffer and the media players client buffer the same thing? If not how do they react? **[ID] [Nov/Dec-2015]**  
No, they are not the same thing. The client application reads data from the TCP receive buffer and puts it in the client buffer. If the client buffer becomes full, then application will stop reading from the TCP receive buffer until some room opens up in the client buffer.
7. What is meant by streaming stored audio and video? **[D] [Nov/Dec-2014]**  
Streaming live audio/video is similar to the broadcasting of audio and video by radio and TV stations. Instead of broadcasting to the air, the stations broadcast through the Internet. There are several similarities between streaming stored audio/video and streaming live audio/video. They are both sensitive to delay; neither can accept retransmission. However, there is a difference. In the first application, the communication is unicast and on-demand. In the second, the communication is multicast and live. Live streaming is better suited to the multicast services of IP and the use of protocols such as UDP and RTP. Examples: Internet Radio, Internet Television (ITV), Internet protocol television (IPTV)
8. Define the best effort service and give an example. **[D] [Nov/Dec-2014]**  
The IP based Internet phone and Real-time video conferencing services are called the best effort services because these services do not make any promise for minimum end-to-end delay or minimum jitter or minimum lose of packets. Retransmission of lost packets is generally not acceptable for interactive real-time audio application. Internet takes its best effort to move each datagram from its source to destination.
9. Is there any advantage in combining RTP and RTSP protocol? Why? **[D] [May/Jun-2016]**  
RTSP is an application-level protocol designed to work with lower-level protocols like RTP, RSVP to provide a complete streaming service over internet. It provides means for choosing delivery channels (such as UDP, multicast UDP and TCP), and delivery mechanisms based upon RTP.

10. Define latency. [D] [May/Jun-2016]

Latency is the amount of time a message takes to traverse a system (Or) time taken for a packet of data to get from one designated point to another.

11. Give the applications of real time streaming protocol. [D] [Apr/May-2015]

Real Time Streaming Protocol(RTSP) is used by the client application to communicate to the server information such as the requesting of media file, type of clients applications, mechanism of delivery of file & other actions like resume, pause, fast forward & rewind. It is mostly used in entertainment & communication system to control streaming media servers.

12. Write the shortcomings of integrated services. [D][Apr/May-2015]

The shortcoming of integrated service (intserv) is that, the per-flow resource reservation may give significant workload to routers & also it does not allow more qualitative definitions of service distinctions.

13. List the fundamental characteristics of multimedia networking application. [D][Nov/Dec-2017]

- ✓ Streaming Video
- ✓ IP telephony
- ✓ Internet Radio
- ✓ Teleconferencing
- ✓ Interactive games
- ✓ Virtual worlds
- ✓ Multimedia web

14. Draw and explain the real time streaming protocol operations. [D] [Nov/Dec-2017]

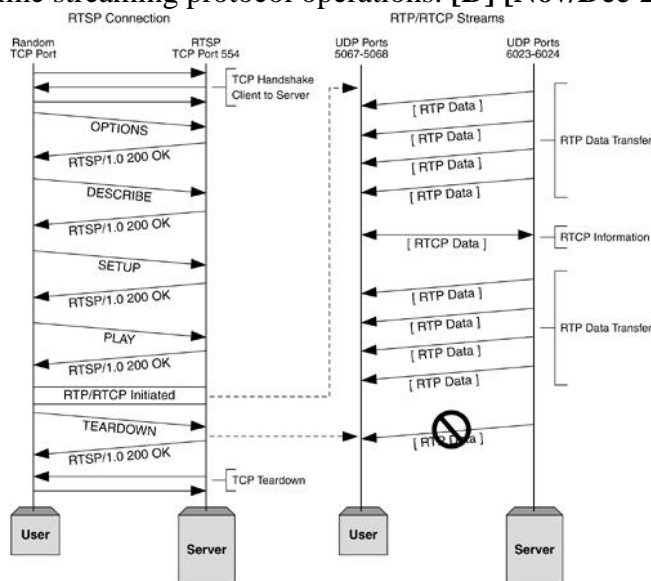

15. List the multimedia networking applications? [D]

- 1) stored streaming
- 2) Live streaming
- 3) Interactive, real-time

16. Define jitter. [D]

Jitter is defined as a variation in the delay of received packets. Due to network congestion, improper queuing, or configuration errors, this steady stream can become lumpy, or the delay between each packet can vary instead of remaining constant.

17. What is end to end delay? [D]

End-to-end delay or one-way delay (OWD) refers to the time taken for a packet to be transmitted across a network from source to destination.

18. Define RSVP? [D]

Resource Reservation Protocol (RSVP) is a transport layer protocol used to reserve network resources and enable running Internet applications to gain quality of service (QoS).

19. List the losses in real time interactive applications. [D]

- ✓ network loss: IP datagram lost due to network congestion (router buffer overflow)
- ✓ delay loss: IP datagram arrives too late for playout at receiver

20. Define RTSP. [D]

The Real Time Streaming Protocol (RTSP) is a network control protocol designed for use in entertainment and communications systems to control streaming media servers. The protocol is used for establishing and controlling media sessions between end points

21. Define RTCP? [D]

The RTP Control Protocol (RTCP) is a sister protocol of the Real-time Transport Protocol (RTP). RTCP provides out-of-band statistics and control information for an RTP session.

22. Define the term quality of service. [D]

In VoIP quality means, being able to listen and speak in a clear and continuous voice. This is affected by the packets lost and the delay (create jitter) occurring in receiving the packets.

23. What is meant by streaming? [D]

Streaming means to playback the media (audio or video) while it is being received through the network i.e. playback starts immediately after a small part of the media is received at the same time the remaining part continues to download, it need not wait for the complete file to download before starting the playback .

24. What are the applications of streamed stored audio and video in multimedia communications? [D]

- ✓ Streaming Audio - Audio on demand e.g. online musical stores, Internet Radio.
- ✓ Streaming Video – Video on demand (VoD) e.g. You Tube, Internet TV, Virtual Class rooms.

25. Name any two packet loss recovery schemes. [D]

- ✓ Forward-error Correction
- ✓ interleaving

26. Write about scheduling and policing mechanisms. [D]

- ✓ First-in-First-out, Priority queuing, Round Robin and Weighted Fair Queuing are the scheduling mechanisms.
- ✓ Leaky bucket mechanism along with Weighted Fair Queuing is used for policing.

27. What are the policing mechanisms adopted in multimedia networks? [D]

Leaky bucket mechanism along with Weighted Fair Queuing is adopted for policing in multimedia networks.

28. Give the importance of RSVP. [D]

RSVP is a signaling protocol that allows the applications running in the hosts to reserve resources like bandwidth and router buffers in the Internet to guarantee QoS.

29. Define packet loss. [D]

Packet loss occurs when one or more packets of data travelling across a computer network fail to reach their destination. Packet loss is either caused by errors in data transmission, typically across wireless networks or network congestion.

30. Define FIFO. [D]

FIFO. Stands for "First In, First Out." FIFO is a method of processing and retrieving data. In a FIFO system, the first items entered are the first ones to be removed.

31. What is WFQ? [D]

Weighted fair queuing (WFQ) is a method of automatically smoothing out the flow of data in packet-switched communication networks by sorting packets to minimize the average latency and prevent exaggerated discrepancies between the transmission efficiency afforded to narrowband versus broadband signals.

## **PART – B FIRST HALF**

### **Multimedia networking -Applications-streamed stored and audio-making the best Effort service**

1. Give a detail notes on Multimedia protocols for real time interactive applications with an example. (16) [D] [Apr/May-2017]
2. Discuss on any one methodology used to make high quality networked multimedia applications a reality. (8) [ID] [Nov/Dec-2015]
3. Explain the various broadcast schemes for video on demand scenario in detail. (16) [D] [May/Jun-2016]
4. Explain about the delay that an internet phone needs to face. (16) [D] [Nov/Dec-2017]
5. How will you classify multimedia applications based on QOS parameters? (8) [D] [May/Jun-2016]
6. Explain the various bit rates ATM forum supports. (8) [D] [May/Jun-2016]

### **Protocols for real time interactive Applications**

1. Explain in detail about RTP.(8) [D] [Nov/Dec-2017]
2. Explain the information contained in RTCP packet types. (12) [D] [EC2037-Nov/Dec-2017]
3. List out RTCP packets types. (4) [D] [EC2037-Nov/Dec-2017]
4. Summarize the important points on: (i) SIP (4) (ii) H323 (4) [D] [EC2037-Nov/Dec-2017]

### **Distributing multimedia-beyond best effort service**

1. Compare best effort and differentiated services. (8) [D] [Apr/May-2015]
2. Write short notes on:
  - (i) Limitations of Best effort service. (5) [D] [Nov/Dec-2015]
  - ii) Real time interactive audio and video. (5) [D] [Nov/Dec-2015]
  - iii) Content distribution networks. (6) [D] [Nov/Dec-2015]
3. Explain the four main RTP packet header fields. (8) [D] [Nov/Dec-2015]

## **PART – B SECOND HALF**

### **Scheduling and policing Mechanisms**

1. Describe the different scheduling mechanisms suitable for multimedia systems with suitable diagrams. (8) [D] [Nov/Dec-2016]
2. Explain the policing mechanisms adopted in multimedia networks with necessary diagrams. (8) [D] [Nov/Dec-2016]
3. Describe the different scheduling and policing mechanisms suitable for multimedia systems with suitable diagrams. (16) [D] [Nov/Dec-2014]
4. Explain in detail about scheduling and policy mechanism.(8) [D] [Nov/Dec-2017]
5. Describe the principle and applications of scheduling and policing mechanisms for providing QoS guarantees. (16) [D] [Apr/May-2015]
6. Summarize the important points on: i) Leaky bucket (4) (ii) WFQ (4) [D] [EC2037-Nov/Dec-2017]



## **Integrated services-differentiated Services-RSVP**

1. Give a brief note on integrated and differential services. (8) [D] [Apr/May-2017]
2. Explain the principle and applications of RSVP. (8) [D] [Apr/May-2017]
3. Explain the integrated services with necessary diagrams. (8) [Nov/Dec-2014]
4. Write a brief note on RSVP. (8) [D] [Nov/Dec-2014]
5. Explain the principle of RSVP. (8) [D] [Apr/May-2015]
6. Give an overview of integrated services. (8) [D] [Nov/Dec-2016]
7. Write a detailed note on differentiated services. (8) [D] [Nov/Dec-2016]

\*\*\*\*\*